

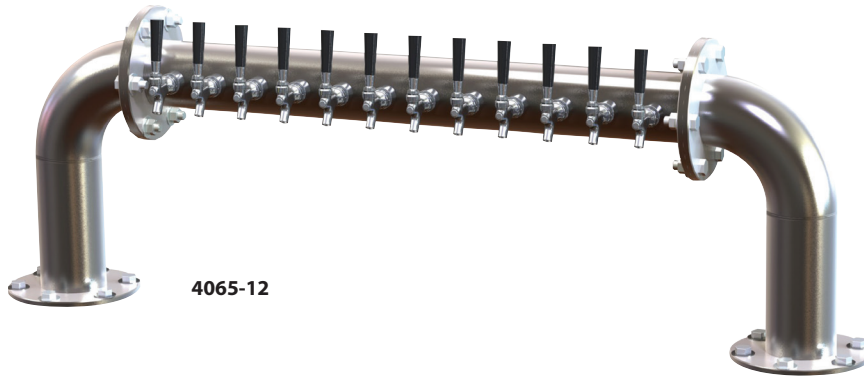

BREW PIPE TOWERS
"L" And Pass-Thru

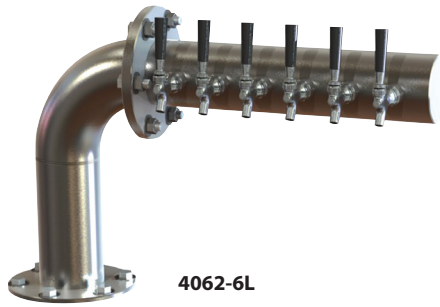

JOB
AREA
ITEM NO.
MODEL NO.

Models	
"L" Brew Pipe Towers	
4062-6L	4062-6R
4062-8L	4062-8R
4062-10L	4062-10R
Pass-Thru Brew Pipe Towers	
4064-6L	4064-6R
4064-8L	4064-8R
4064-10L	4064-10R
	4065-12
	4065-16
	4065-20

KEY PRODUCT FEATURES AND BENEFITS

- Robust pipes and flanges are durable and offer an industrial feel that makes a statement in the space
- Solid metal construction with brushed stainless pipe to withstand years of use
- Pure copper coolant lines and cold block maintain chilled beverage temperature
- Insulated dispensing head ensures a perfect temperature right up to the faucet

ACCESSORIES

MODEL NOS.	DESCRIPTION
630SS	Stainless Steel Forward Sealing Faucet
650SS	Stainless Steel Forward Sealing Faucet w/ Flow Control
680SS	Stainless Steel Faucet with Push-back Creamer
690SS	Stainless Steel Flow Control Faucet with Push-back Creamer
63927	Stout and Ale faucet - Stainless steel body and spout
308-40C	Beer faucet lock for 630 Series Faucets
67141	Perlick Pub handle - 7-1/2" wooden handle

* Faucets sold separately

Form No. 95150
Rev. 04.05.2022

MODEL NUMBERS - 4062-6L, 4062-6R, 4062-8L, 4062-8R, 4062-10L, 4062-10R, 4064-6L, 4064-6R, 4064-8L, 4064-8R, 4064-10L, 4064-10R, 4065-12, 4065-16, 4065-20



BREW PIPE TOWERS
"L" And Pass-Thru

"L" BREW PIPE TOWER

NUMBER OF FAUCETS		6	8	10
MODEL NUMBERS	Left Mount	4062-6L	4062-8L	4062-10L
	Right Mount	4062-6R	4062-8R	4062-10R
"A", LENGTH (MM)		28-3/4" (730)	34-11/16" (881)	40-5/8" (1032)
"B", HEIGHT (MM)		17-3/4" (451)	17-3/4" (451)	17-3/4" (451)
FAUCET CENTERS (MM)		3" (76)	3" (76)	3" (76)
MATERIAL AND FINISH		4" Schedule 5 Stainless Steel Pipe, Matte Finish		
SHIPPING WEIGHT, LBS. (KG)		80 (36)	95.5 (43)	111.5 (50)
OPTIONAL DRIP PAN		C18750-21	C18750-27	C18750-33

PASS-THRU BREW PIPE TOWER

NUMBER OF FAUCETS		6	8	10	12	16	20
MODEL NUMBERS	Beer Leads Left	4064-6L	4064-8L	4064-10L	-	-	-
	Beer Leads Right	4064-6R	4064-8R	4064-10R	-	-	-
	Beer Leads Left and Right	-	-	-	4065-12	4065-16	4065-20
"A", LENGTH (MM)		37-9/16" (954)	43-5/8" (1108)	49-9/16" (1259)	55-1/2" (1410)	67-1/2" (1715)	79-3/8" (2016)
"B", STANDARD HEIGHT (MM)		12-15/16" (329)	12-15/16" (329)	12-15/16" (329)	12-15/16" (329)	12-15/16" (329)	12-15/16" (329)
"C", CENTER TO CENTER (MM)		33-1/8" (843)	39-1/8" (994)	45-1/8" (1146)	51-1/8" (1298)	63" (1600)	74-7/8" (1902)
FAUCET CENTERS (MM)		3" (76)	3" (76)	3" (76)	3" (76)	3" (76)	3" (76)
MATERIAL AND FINISH		4" Schedule 5 Stainless Steel Pipe, Matte Finish					
SHIPPING WEIGHT, LBS. (KG)		101 (45)	107 (48)	133 (60)	149.5 (67)	183 (83)	216 (97)
OPTIONAL DRIP PAN		C18750-21	C18750-27	C18750-33	C18750-39	C18750-51	C18750-63

MODEL NUMBERS - 4062-6L, 4062-6R, 4062-8L, 4062-8R, 4062-10L, 4062-10R, 4064-6L, 4064-6R, 4064-8L, 4064-8R, 4064-10L, 4064-10R, 4065-12, 4065-16, 4065-20



BREW PIPE TOWERS
"L" And Pass-Thru

MODEL NUMBERS - 4062-6L, 4062-6R, 4062-8L, 4062-8R, 4062-10L, 4062-10R, 4064-6L, 4064-6R, 4064-8L, 4064-8R, 4064-10L, 4064-10R, 4065-12, 4065-16, 4065-20

