

PERLICK ACCESSORY KIT INSTRUCTIONS FOR CR-ACC-D1

DUAL INSTALLATION INSTRUCTIONS WITH HEATER PANEL (HANDLE TO HANDLE)

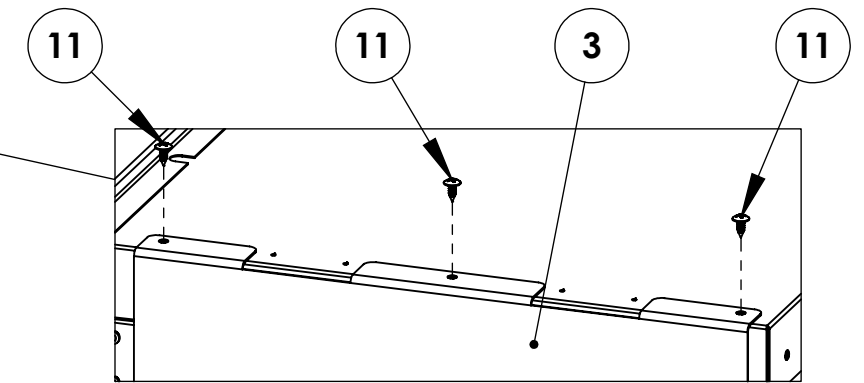

STEP #2: DETERMINING WHICH CABINET WILL BE ON THE LEFT SIDE. ATTACH THE "SIDE BY SIDE HEATER ASSEMBLY" (1010469) TO THE RIGHT SIDE OF THE LEFT CABINET WITH (3) M50050-466.

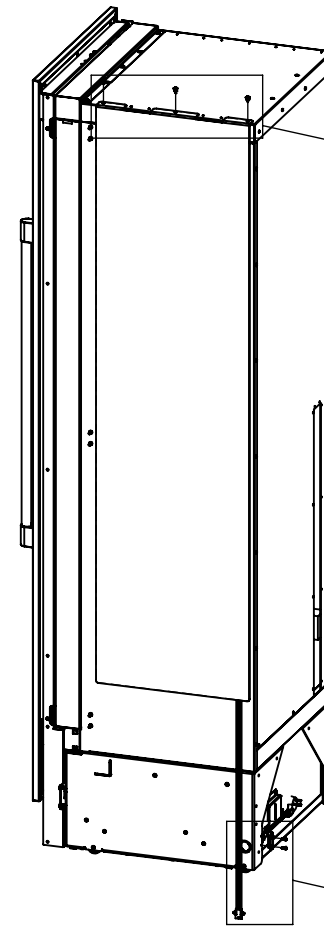
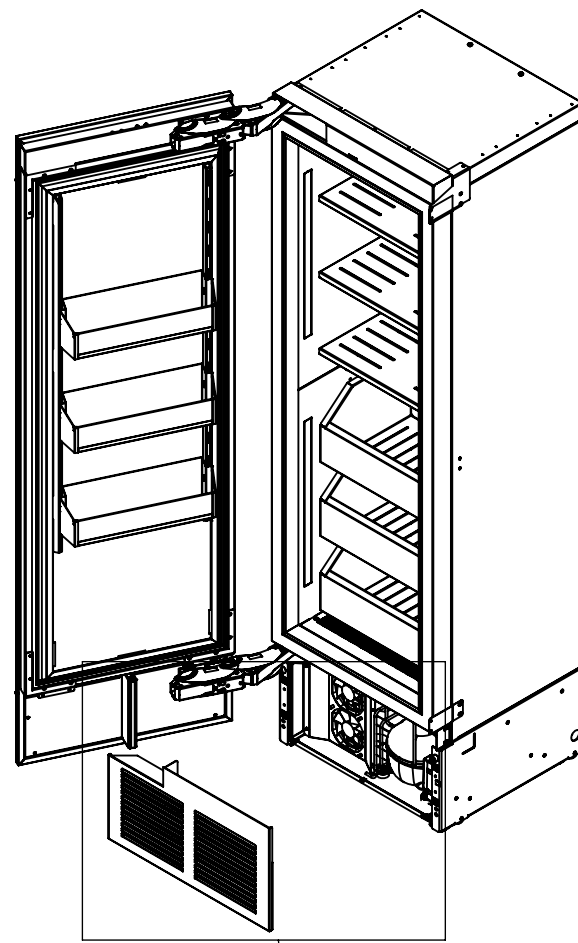
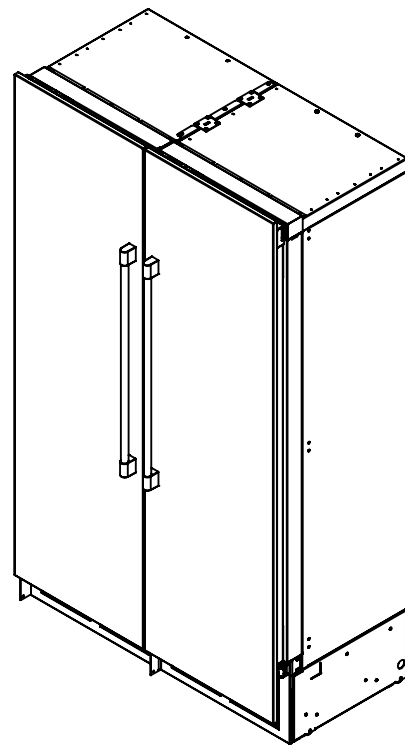
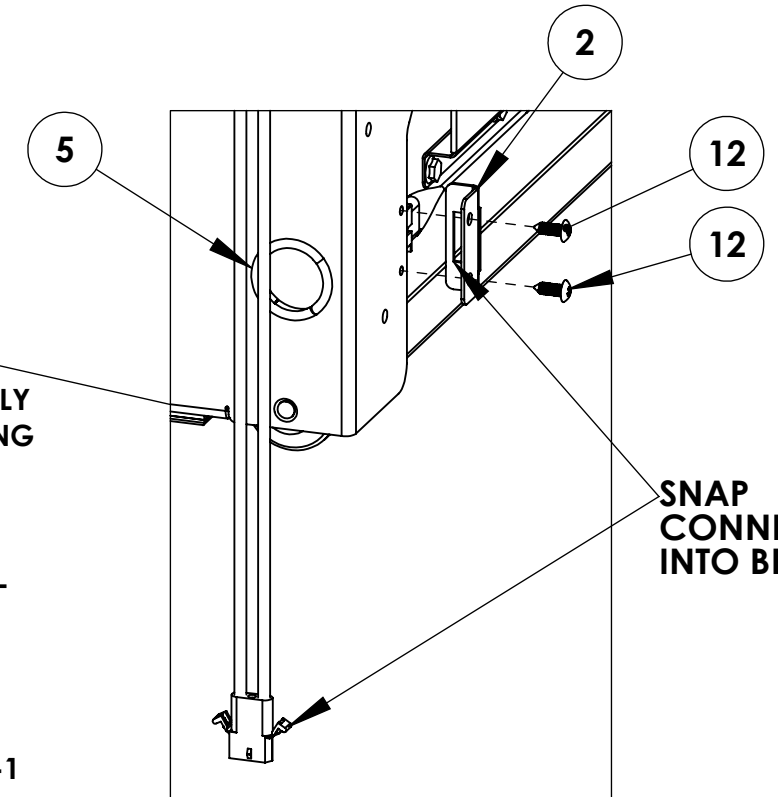

STEP #3: ONCE THE HEATER ASSEMBLY IS ATTACHED, SNAP (1) 1-1/4" BUSHING INTO THE SIDE OF THE CABINET.

STEP#4: RUN THE WIRES FROM THE HEATING ASSEMBLY THROUGH THE 1-1/4" BUSHING AND SNAP THE END CONNECTOR INTO THE CUT OUT OF BRACKET 1009975-1

STEP #5: ATTACH BRACKET 1009975-1 WITH (2) M50095-122. CAUTION: DO NOT PINCH WIRES FROM HEATING ASSEMBLY.

SNAP CONNECTOR INTO BRACKET

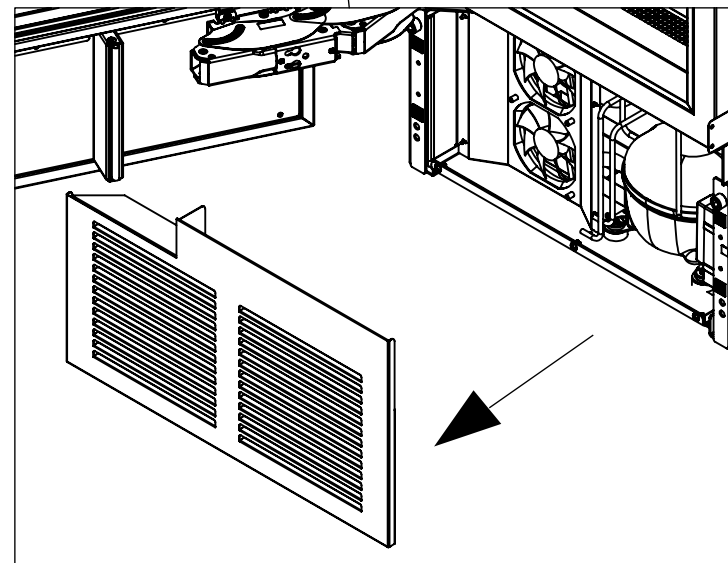
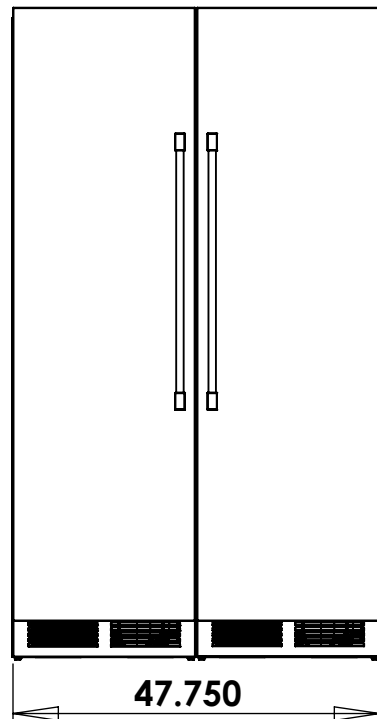

STEP #1: OPEN THE DOORS TO THE CABINETS. GRAB BOTH SIDES OF THE FRONT GRILL PLATE AND PULL STRAIGHT OUT IN ORDER TO POP THE CLIPS OUT OF THE LATCHES. DO THIS TO BOTH CABINETS.

ITEM NO.	PART NUMBER	DESCRIPTION	Default/QTY.
1	1008781	SCREW, M6 X 12MM, THRD	8
2	1009975-1	BRACKET, MOUNTING, MACHINE COMP. WIRE HARNESS, COLUMN	1
3	1010469	SIDE BY SIDE HEATER ASSEMBLY, COLUMN	1
4	1010546	M5x10 MACH SCR, LOW HEAD, NBK PART NO: SSH-M5-10	6
5	1010667	BUSHING, SPLIT, 1-1/4" HOLE, BLACK, HEYCO 2881	1
6	1012862	POWER CORD KIT	1
7	1013719-1	BRACKET, ATTACHING, COLUMN, FOR SIDE BY SIDE INSTALLS	4
8	1015035-1	CENTER TRIM, SIDE BY SIDE INSTALL, COLUMN	1
11	M50050-466	#10 X 1/2" PH Truss Head SMS #410 S.S., Type "AB",	11
12	M50095-122	Screw, Sheet Metal, #10-16 x 1/2" Thin-Lock TM, PH Undercut Pan	2

D 47.75" WAS 49" 2/05/2019

C UPDATE INSTRUCTION LAYOUT 5/30/2018

REVISIONS

SCALE: 1:50

DR.: UO DATE: 12/12/2017

1014974

SHEET 1 OF 2



PERLICK CORPORATION
MILWAUKEE, WI 53223

PROPERTY OF THE PERLICK CORP.
NOT TO BE COPIED OR USED DETRIMENTAL TO OUR INTERESTS

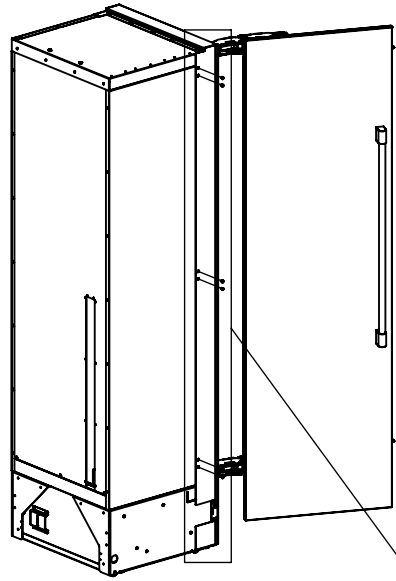
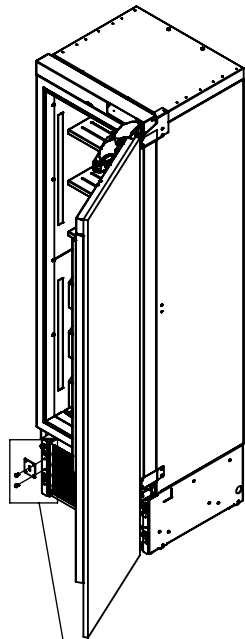

STEP #7: REMOVE ALL PROTECTIVE FILM FROM THE CENTER TRIM (1015035-1).

STEP #8: ATTACH THE CENTER TRIM TO LEFT SIDE OF THE CABINET THAT WILL BE ON THE RIGHT, WITH (6) 1010546. BEFORE FULLY TIGHTENING SCREWS, MAKE SURE THE CENTER TRIM SITS FLUSH WITH THE CABINET FACE.

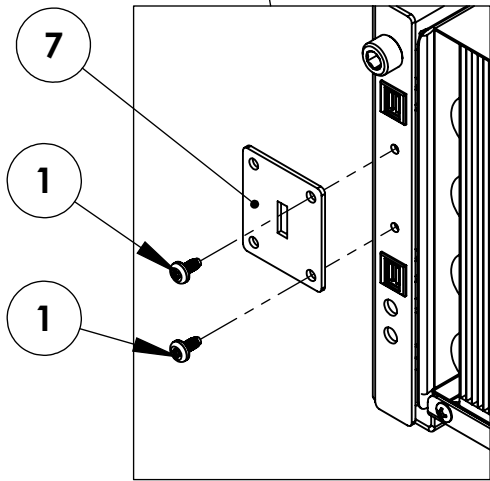

STEP #6: SELECT THE CABINET THAT WILL BE PLACED ON THE RIGHT SIDE. SECURE (1) 1013719-1 TO THE FRONT BASE WITH (2) 1008781 SCREWS

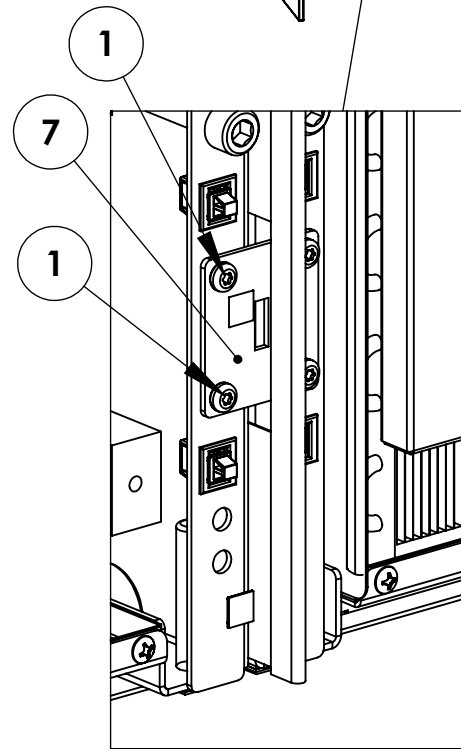
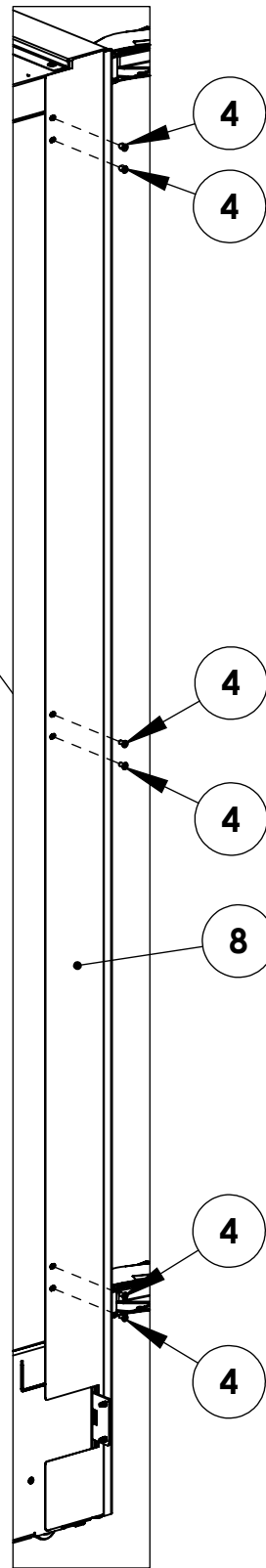

STEP #9: MOVE BOTH CABINETS DIRECTLY NEXT TO EACH OTHER SO THAT THE LEFT CABINET COMES IN CONTACT WITH THE CENTER TRIM.

STEP #10: SECURE BOTH CABINETS TOGETHER BY SECURING THE "ATTACHING BRACKET (1013719-1)," PREVIOUSLY SECURED TO THE RIGHT CABINET, TO THE LEFT CABINET WITH (2) 1008781 SCREWS.

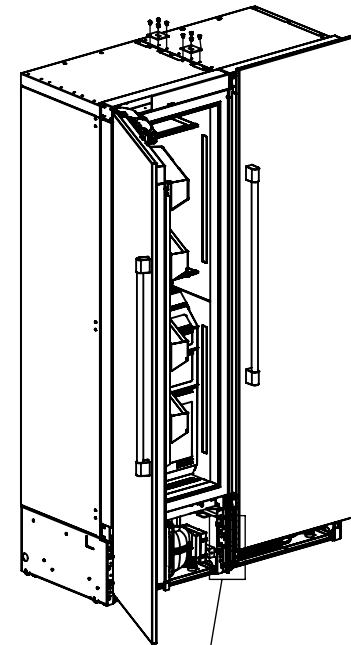

STEP #11: SECURE BOTH CABINETS TOGETHER AT THE TOP WITH (2) 1013719-1 AND (8) M50050-466

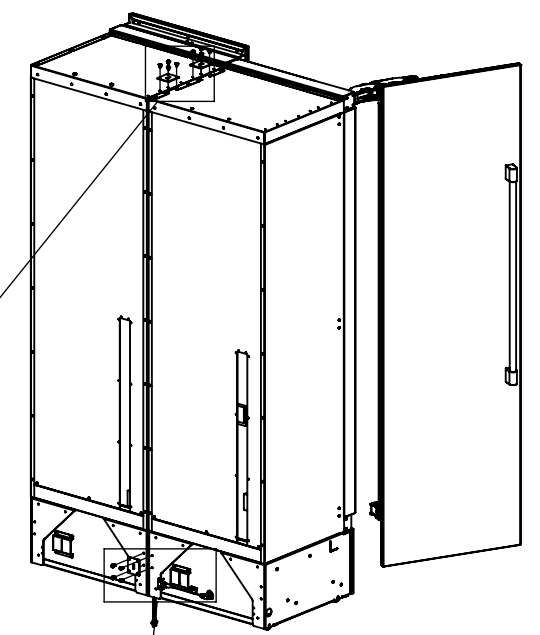
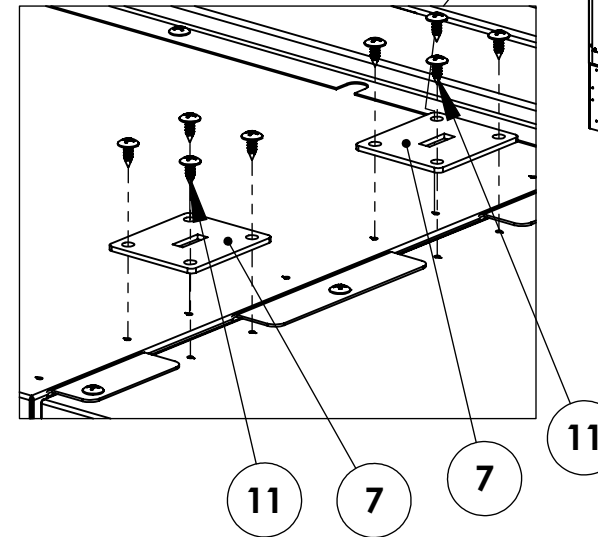

POWER CORD FOR HEATING ASSEMBLY

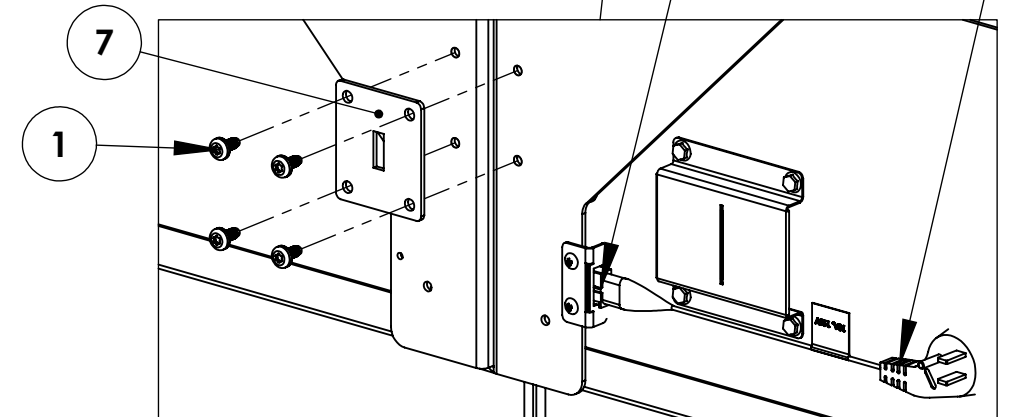

STEP #12: SECURE BOTH CABINETS TOGETHER AT THE BACK WITH (1) 1013719-1 AND (4) 1008781

STEP #13: ONCE ALL BRACKETS HAVE BEEN SECURED IN PLACE, ATTACH THE FRONT GRILLS BACK ONTO THE UNIT.

STEP #14: PLUG POWER CORD (1012862) INTO HEATING ASSEMBLY CONNECTOR
NOTE: HEATING ASSEMBLY CAN UTILIZE SAME ELECTRICAL CIRCUIT AS THE CABINET

SCALE: 1:50
DR.: UO DATE: 12/12/2017

1014974
SHEET 2 OF 2



PERLICK CORPORATION
MILWAUKEE, WI 53223

PROPERTY OF THE PERLICK CORP.
NOT TO BE COPIED OR USED DETRIMENTAL TO OUR INTERESTS